

REMADUST



> > > The efficient dust sealing system

REMADUST is a dust sealing system which minimises dust emissions and reduces noise levels. It is characterised by its high levels of elasticity and rupture strength. Its long-lasting weather-resistance means it can be used in a wide range of sectors throughout industry. This means *REMADUST* can guarantee virtually dust-free operation in many conveyor and processing systems and increase profitability by reducing maintenance and assembly costs.

Dust-sealing elastic connection between vibratory feeder and rigid discharge hoppers.



With its excellent range of benefits, *REMADUST* can solve your dust problems too:

- Simple to fit (using clamping profiles)
- Dust sealing rubber blanket with high wear resistance
- Minimal maintenance costs
- Significant reduction of dust content
- Reduced amount of extraction air required
- Considerable sound diminution

REMADUST – excellent functionality for the most diverse areas of application:

- Screening machines
- Workstations
- Conveyor systems
- Pressure wells
- Chutes, etc.



One Name – One Source – One System

REMADUST

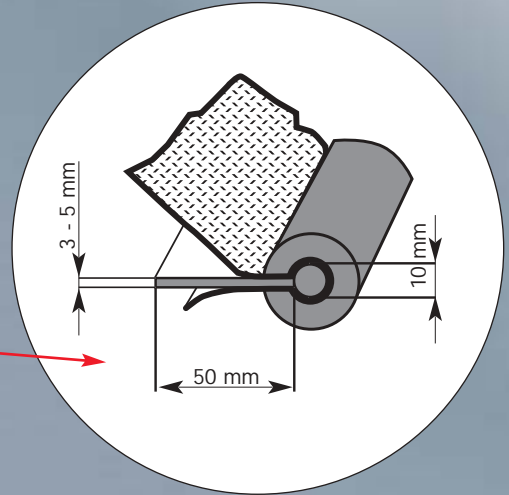
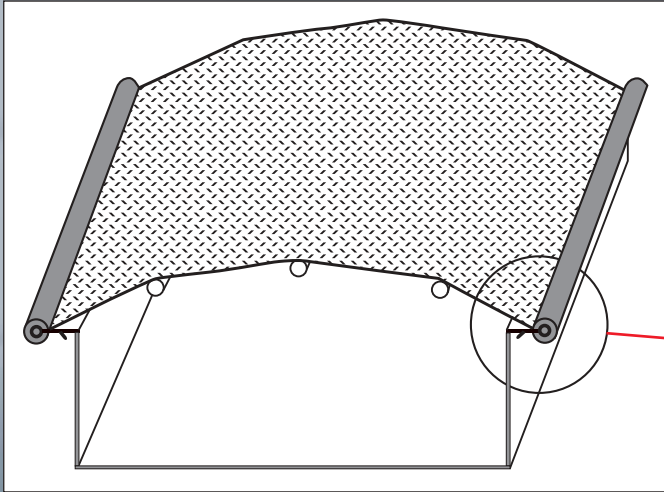

>>> **REMALINE 25**: the dust sealing blanket with textile pattern on both sides. Its specific product characteristics make it particularly strong on performance:

- Highly elastic
- Extremely high tear propagation strength
- Weather resistant
- Hardness: 35 ± 5 Shore A
- Colour: black
- Dimensions: 2 x 1,350 x 20,000 mm

>>> Also available in our qualities **REMALINE 40 S** (flame resistant) and **REMALINE 70 V** (self-extinguishing).

>>> **REMA TIP TOP** clamping profiles, delivery formats:

For \varnothing 14 mm (i.e. 10 mm round steel and 2 mm thick dust sealing blanket)

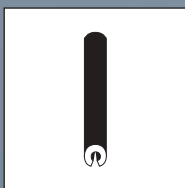

• Clamping profile
Dimensions:
35 m roll

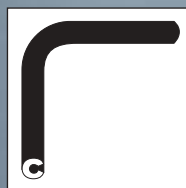

Internal groove

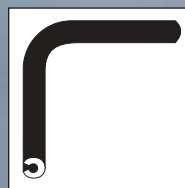

External groove

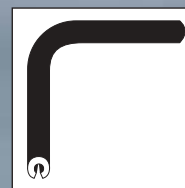

Groove on underside

• 90° corner clamping profile

Dimensions:
approx. 205 x 205 mm
(External \varnothing = 31 mm:
Radius to centre of
groove: approx. 55 mm)

TIP TOP Industrie

TIP TOP Industrie

A business unit of STAHLGRUBER Otto Gruber GmbH & Co KG
Gruber Straße 63 • 85586 Poing / Munich / Germany

Tel.: +49 (0)8121 - 707 - 234 • Fax: +49 (0)8121 - 707 - 222

More information is available at:
www.rema-tiptop.com • info-industrie@tiptop.de

Your local contact: